



MODEL AT 40
RATED CAPACITY MANUAL
Book Part Number: T156318D



HYDRAULIC MOBILE ARTICULATED PICK & CARRY CRANE

40 tonne MAXIMUM RATED CAPACITY

**Do not operate this crane unless you have read
and understood the information in this book.**

Terex Australia Pty. Ltd.

ABN : 86 010 671 048
E-Mail : info@terex.com.au

CONTENTS

WARNINGS 3
OPERATIONAL NOTICE 3
ATTACHMENT NOTICE 3

DEFINITIONS 4

SPECIAL PRECAUTIONS FOR ARTICULATED CRANES 5
GENERAL 5
SET-UP 5
OPERATION 6
LIFT AND CARRY OPERATION..... 7

OPERATION ON SLOPE 8

SPECIFICATIONS 9

CRANE CONFIGURATION 11

RATED CAPACITY CHARTS..... 12
101: FB - FALL BLOCK – STATIC 13
101: FB - FALL BLOCK – PICK AND CARRY 14
102: RH20 - RHINO HOOK 20t – STATIC 15
102: RH20 - RHINO HOOK 20t – PICK AND CARRY 16
103: RH15 - RHINO HOOK 15t – STATIC 17
103: RH15 - RHINO HOOK 15t – PICK AND CARRY 18
110: FLUG - FIXED LUG – STATIC..... 19
110: FLUG - FIXED LUG – PICK AND CARRY 20
111: LUG1 - LUG 1 – STATIC..... 21
111: LUG1 - LUG 1 – PICK AND CARRY..... 22

AFTERMARKET CONTACTS LIST..... 23

NOTE: ALL PAGES MUST BE INCLUDED IN THIS BOOK.

WARNINGS

OPERATIONAL NOTICE



IMPROPER CRANE USE, CARE OR OPERATION
CAN CAUSE INJURY, DEATH OR PROPERTY
DAMAGE.

DO NOT OPERATE THIS MACHINE UNLESS YOU
HAVE READ AND UNDERSTAND THE OPERATOR'S
MANUAL AND CRANE RATED CAPACITY MANUAL.

COPIES OF OPERATOR'S MANUALS AND CRANE RATED CAPACITY
MANUAL MAY BE OBTAINED FROM:



ATTACHMENT NOTICE



WRITTEN AUTHORISATION IS REQUIRED FROM
TEREX AUSTRALIA PTY LTD PRIOR TO THE USE OF
ANY ATTACHMENT NOT SPECIFIED IN THE MANUAL.

DEFINITIONS

Articulation – The crane pivots in the middle to allow steering and slewing of the load. See *Working Area diagram*

Deration – A decrease in the Rated Capacity due to external influences, expressed as a percentage.

Freely Suspended Load – Load hanging free with no direct external force applied except by the winch rope.

Gradient: Generalised slope of ground measured as a percentage.

Load Radius – The horizontal distance from the centre of the freely suspended hoisting hook perpendicular to a vertical plane containing the front axle.

Loaded Boom Angle – This is given to assist in setting up the crane only. It gives only an approximation of the Load Radius for a specified boom length. “Boom Angle” on Rated Capacity charts refers to the angle between the boom and true horizontal. (Refer to image below)

Load Moment Indicator (LMI) - A system that displays rated capacity for the given configuration. An audible warning sounds when rated capacity is approached and reached.

Pitch Angle – The forward tilt of the crane, the angle between the chassis of the front of the crane and true horizontal in the longitudinal direction. The pitch is positive when the front is higher than the rear. In the image shown, the pitch angle is negative.

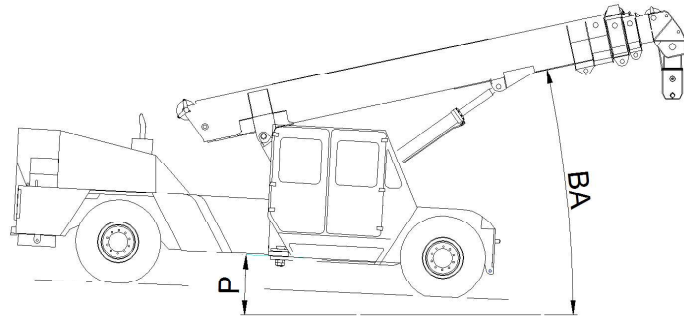

Rated Capacity (RC) – The total Freely Suspended Load, including the mass of material and load handling equipment, that the machine can safely lift under ideal conditions at a given configuration.

Roll – The side tilt of the crane chassis, the angle between the front chassis of the crane and true horizontal. The roll angle is positive when the left side of the crane is higher than the right side. In the image shown, which is a view on the front of the crane, the roll angle is negative.

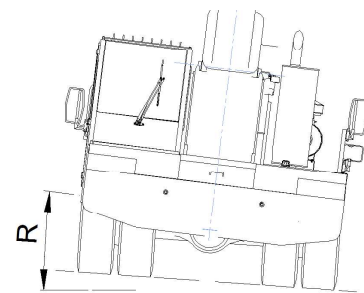

Side Load – Any external force applied either to the boom or load in a horizontal direction.

Slope: Generalised angle of the ground measured in degrees.

Tilt: Generalised combination of pitch and roll.

Work Areas – Area measured in an arc about the centre pivot as shown on the Working Area diagram.

SPECIAL PRECAUTIONS FOR ARTICULATED CRANES

THERE IS A POTENTIAL FOR CRUSHING BETWEEN FRONT AND REAR CHASSIS WHEN THE MACHINE ARTICULATES. NEVER STAND IN THE PIVOT AREA WHEN THE ENGINE IS RUNNING OR EMERGENCY STEERING PUMP IS OPERATING. ALWAYS REMOVE THE KEY FROM THE IGNITION BEFORE WORKING IN THE PIVOT AREA.

GENERAL

1. This machine has been designed to meet the requirements of AS1418.1 (2002) & 1418.5 (2013) and has been tested in accordance with these standards for pick and carry operation on tyres. The machine classification is A3.
2. Rated Capacities shown are for this machine as originally manufactured by Terex Australia Pty Ltd. The Rated Capacities only apply when all the instructions in this book are rigidly followed. Modifications to this machine or use of equipment other than that specified can result in a reduction in Rated Capacity.
3. If improperly operated or maintained, this machine can be hazardous. Operation and maintenance of this machine must be in compliance with the information documented in this rated capacity manual and in the operators, service and parts manuals furnished. If these manuals are missing, obtain replacements through Terex Australia Pty Ltd or their agents.

SET-UP

4. Reduced crane Rated Capacities for the particular job shall be established, by the operator, with due allowance for adverse operating conditions. These conditions include the supporting surface, pendulum action of the load, jerking or sudden stops of the load and other factors affecting stability, two machine lifts, electrical wires, adverse weather, wind, hazardous surroundings, experience of personnel, etc.
5. Rated Capacity is based on Freely Suspended Loads. Lifting, or travelling (pick and carrying) with a load, on soft or uneven ground can be hazardous and will reduce the Rated Capacity of the crane. Refer to the section "Operation on Slope" for further information.
6. No attempt shall be made to drag the load along the ground in any direction.
7. Wind forces on the boom, resulting from winds up to 10 m/s (36 km/h), are incorporated in the Rated Capacity. Any additional Side Loading due to wind forces on the load will reduce the Rated Capacity, and must be considered.
8. Rated Capacities include the mass of hooks, blocks, slings and auxiliary lifting devices. Their mass must be subtracted, from the listed Rated Capacity, to determine the equivalent net load.
9. Loaded Boom Angles at specified boom lengths give only an approximation of the Load Radius. The Boom Angle before loading should be greater to account for boom deflection increasing the Load Radius as the load is lifted.

OPERATION

10. Read and understand all warnings and instructional notes.
11. Do not tip the machine to determine allowable lifting capacities.
12. Loads may be lifted from:
 - The main boom head on the winch.
 - The fixed lug.
 - The sliding lug.

Always use the correct Rated Capacity chart for the lifting point in use. Ensure the LMI is set to the correct duty.

NOTE : Written authorisation from Terex Australia Pty Ltd is required prior to the use of any attachment not specified in the manual.

13. Crane mode requires low range to be engaged. Selecting crane mode will automatically engage low range and cause the front suspension lockouts to engage when the suspension activation button is pressed.
14. Lifting from more than one lifting point simultaneously is neither intended nor approved.
15. Handling of personnel from the boom is neither intended nor approved, except by written approval from Terex Australia Pty Ltd.
16. When either the boom length or Load Radius or both are between values listed, the smallest load shown at either the next larger Load Radius or boom length shall be used, or the interpolated value shown on the LMI may be used.
17. Side Loading of the machine and load swing out may cause structural failure or machine tip-over. Side Loads may be generated by:
 - Lifting when not level.
 - Sudden acceleration or deceleration
 - Sudden movement when articulating with a load.
 - Dragging a load.
 - Pushing a load.
 - Wind forces on load and boom structure.
18. It is safe to attempt to telescope any load within the limits of the Rated Capacity Manual. The maximum load that may be telescoped is limited by hydraulic pressure, Loaded Boom Angle and powered boom sections lubrication.
19. Boom extension 1 and boom extension 2 move simultaneously. The winch rope is fully compensated for boom extension when boom extensions 1 & 2 are being telescoped. Boom extension 3 is powered on the AT 40 however there is no compensation of the winch rope as the third extension is being extended.

Operator to take care to extend rope as required while boom extension 3 is being telescoped.
20. Do not allow the winch rope to unwind fully. Always ensure a minimum of 3 wraps of rope remain on the winch drum.

21. Rated Capacity depends on tyre rating, tyre condition and tyre inflation pressure. All tyres must be in good condition and must be inflated to the recommended pressure before attempting a lift.
22. Pick & carry operation is permitted through the full Articulation range, however, Rated Capacity may be reduced by articulation, pitch or roll angle changes. The LMI in the AT 40 dynamically calculates rated capacity taking crane tilt and articulation into account.
23. The maximum speed for pick & carry operation is 0.4m/s (1.44km/h). The transfer case shall be set to low range.
24. Operation of this crane in excess of the Rated Capacity and disregard of the instructions is hazardous.

LIFT AND CARRY OPERATION

Observe the following during travel with load on the crane:

- Keep the boom tip as close to the ground as possible by using:
 - The **MINIMUM** practical boom length
 - The **MINIMUM** practical Boom Angle.
- Keep the load as **CLOSE** to the ground as possible.
- Keep the load as **CLOSE** to the front of crane as possible
- Use the **MINIMUM** Articulation angle practical - **REMEMBER** the crane will side tilt when articulated and hence the hook will move towards the direction of Articulation whilst steering.
- Load swing greatly reduces stability – **REMEMBER** to tagline loads to prevent pendulum motion of the load. Travel and crane motions should be applied gently to minimise this effect.
- Always **REMEMBER**:
 - On flat ground - Increased articulation reduces load capacity
 - On sloping ground – Downhill articulation reduces load capacity.

OPERATION ON SLOPE

The operation on slope of cranes that travel with a freely suspended loads should be avoided if at all possible (refer to AS 2550.5). Mobile Cranes are primarily designed to operate on firm, flat, level ground; within a 1% gradient. Any deviation from this requires that the Rated Capacity shall be reduced (derated) accordingly.

If it is necessary to operate on slope the precautions listed below must be taken.

- **REMEMBER** that surface depressions and potholes will create the same effect as a sloping surface.
- Ensure the ground condition is **FIRM** enough to support the axle loads.
- Ensure the tyres are inflated to the correct operating pressures.
- Keep the load on the **UPHILL** side of the crane where possible. **REMEMBER** the working Load Radius will increase if the load is suspended in the downhill position.

NOTE:

The AT 40 crane must at no time be operated on a slope greater than 5° (8.75% gradient).

In order to determine the slide slope of a particular site the crane's LMI can be used to give an approximation. Before commencing the lift, drive the un-laden crane slowly across the sloping surface and note the maximum slope displayed. Take the reading when the crane's articulation is zero (straight ahead) and with the boom (fully retracted) in its lowest position practical.

The AT 40 is fitted with an LMI that calculates the rated capacity for the crane when the crane tilts in any direction.

SLOPE RATED CAPACITY

The degree of tilt of the front body results from a number of factors. Articulation of the crane induces tilt, as does working on a slope. In combination the body tilt is increased when the load is on the **DOWNHILL** side of the crane (when the crane articulation direction is down a side slope).

The degree of tilt of the front body and boom is further increased by the deflection of the tyres. This is illustrated in Figure 1. For instance, a 5° ground side slope may result in chassis tilt of say 7°.

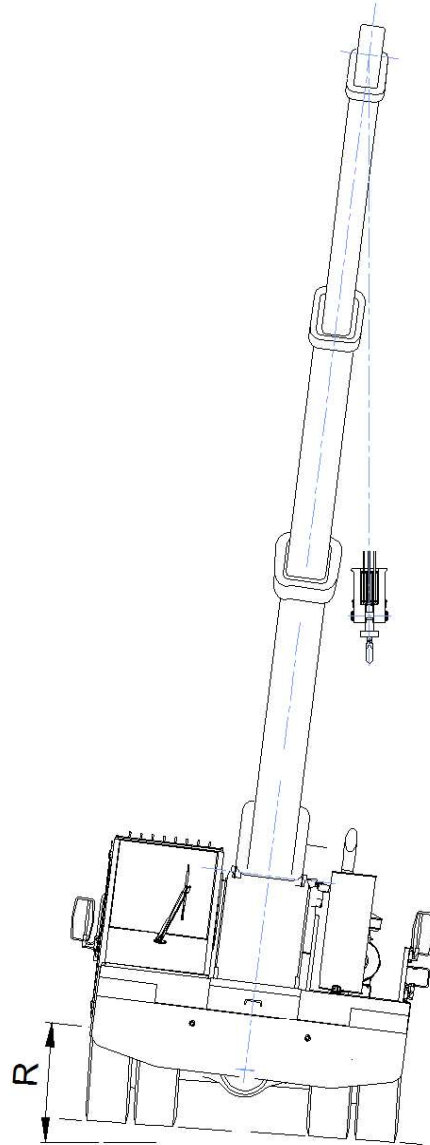

Figure 1

The LMI determines and displays the degree of body tilt measured by a sensor that is attached to the front body. This sensor measures the angle of the front body, not the angle of slope of the ground. When the crane is un-laden, the boom fully down, and the crane is at zero articulation, the body will be close to the same angle as the ground, for up to 5° slope.

This body tilt angle (the “Roll”) is used by the LMI to derate the crane as this is also the angle the boom has been tilted sideways. When lifting or carrying a load in slope situations, the tilt of the body will change as the weight of load is taken by the crane. In most circumstances, this change will be further derate the crane. Hence in planning a lift, it is important to be conservative on lift capacity in any circumstance where the lift will induce significant front body tilt.

SPECIFICATIONS

ATTACHMENT MASSES

Four/six/seven falls hook block	T156389	230 kg
Four/eight falls hook block (including ramshorn hook)	T166952	270 kg
15 tonne Rhino hook	T166910	25 kg
20 tonne Rhino hook	T152947	27 kg
9 tonne hook	PP2190200	10 kg
15 tonne hook	PP2153200	15 kg
25 tonne hook	PP2087500	26 kg
32 tonne hook	T166918	50 kg
15 tonne spreader bar	PL15A8023	107 kg

NOTE : These masses apply only to Terex Australia Pty Ltd supplied equipment.

HOOK BLOCK (FALL BLOCK)

Hook Block:	Number of Falls of Rope	Maximum Hook Block RC (kg)
	2	8700
	4	17500
	6	26200
	7	30600
	8	35000

WIRE ROPE

Wire Rope:	Rope: Non-rotating 2160 MPa	Ø14mm35W x 7
	Minimum Breaking Force:	192 kN
	Rope Length:	122 m
	WLL. (Single line pull)	4,375 kg

TYRE SPECIFICATIONS

Condition	Speed	Rated Capacity (Min)
Pick & Carry Front tyres	<1.44 km/h	13,450 kg per tyre (dual fitment) at 830 kPa (120 psi)**
Pick & Carry Rear tyres		5,300 kg per tyre (dual fitment)
Highway	80 km/h	3,000 kg per tyre (dual fitment)

TYRE INFLATION CHART

Position	Construction	Inflation Pressure	
		Pick & Carry	Highway Travel
Front	385/95 R25	830 kPa ** (120 psi)	830 kPa (120 psi)
Rear	315/80 R22.5	830 kPa (120 psi)	830 kPa (120 psi)

** See Duty 110 for requirement to achieve 100% rated capacity lifts

AT 40 Axle Loads:

Axle loads for un-laden crane, boom fully retracted and boom angle at 0°.

Travel Mode:	Axle 1:	11,000 kg
	Axle 2:	9,250 kg
	Axle 3:	9,250 kg
Axle 3 Raised:	Axle 1:	8,300 kg
	Axle 2:	21,200 kg
	Axle 3:	-

CRANE CONFIGURATION

RANGE DIAGRAM AT 40

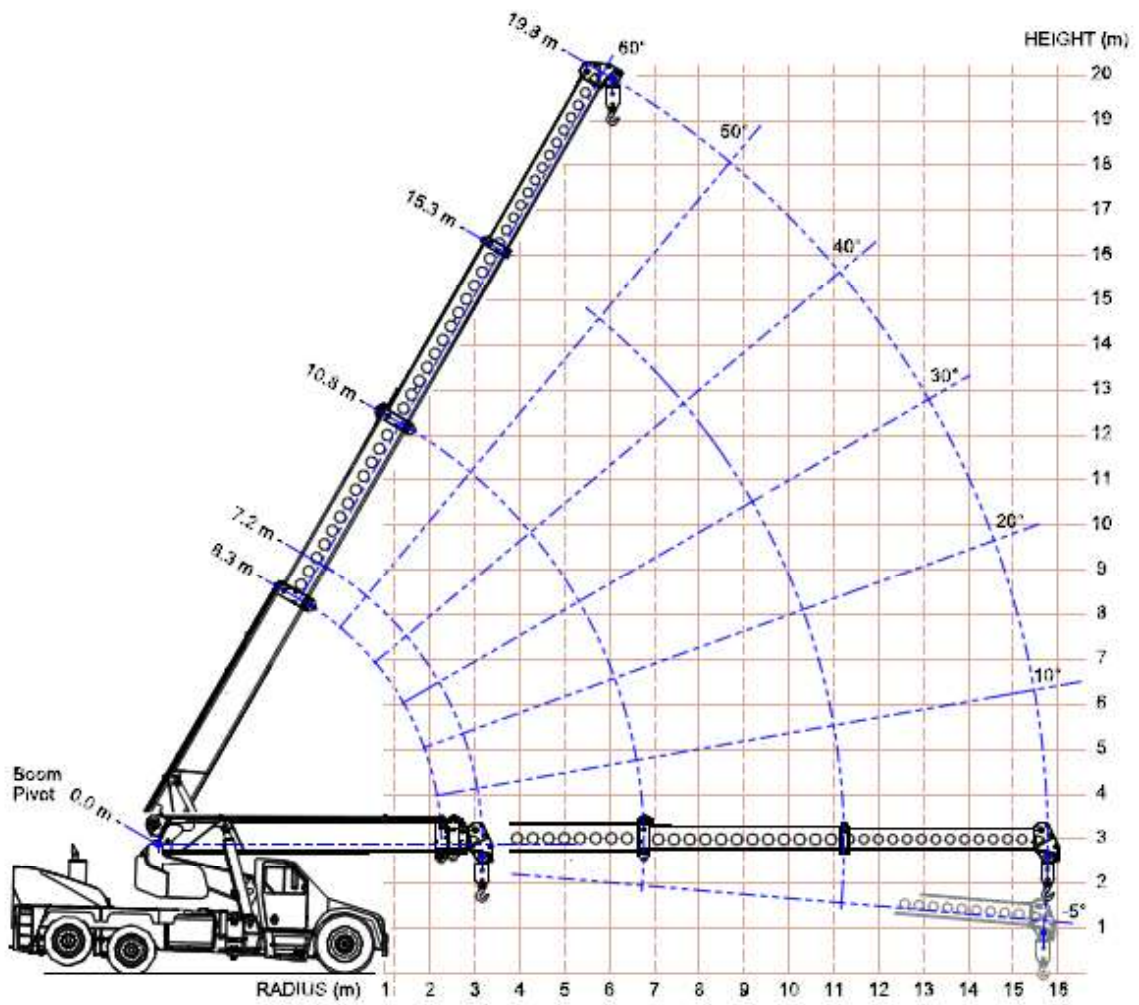

WORKING AREA DIAGRAM AT 40

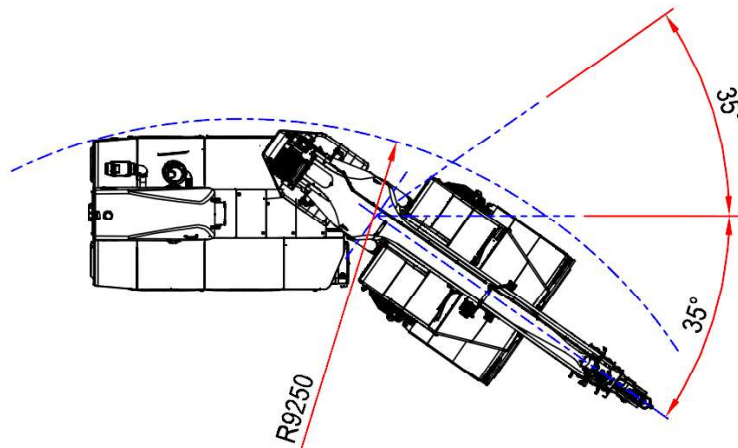

RATED CAPACITY CHARTS

DUTY NUMBERS

Crane lifting configuration (Duty) is designated in this Rated Capacity Manual by the use of a three digit number. This three digit number and description is displayed on the crane's LMI after selection by the operator.

The AT 40 is supplied with both static and pick and carry charts in all duties, under the same duty number. When the crane is stationary, the LMI will display a rated capacity based on the static chart for the particular duty.

Description	Code	Duty Number
Fall Block	FB	101
Rhino Hook 20t	RH20	102
Rhino Hook 15t	RH15	103
Fixed Lug	FLUG	110
Lug 1	LUG1	111

CHART RELATED INFORMATION

- Pitch and Roll angles: Rated capacity values in the charts for the AT 40 crane at 20° & at 35° articulation have been calculated using pitch and roll values consistent with lifting on firm level ground.
- RC are based on firm level ground with tyres at specified pressures. (1% max side slope (0.6°)).

Crane rated capacity calculation for steering articulation and/or slope

The LMI uses a complex algorithm to calculate the crane rated capacity due to the configuration of the crane and slope position. The printed rated capacity manual is only a "snapshot" of what the crane is rated to in the prescribed configuration based on flat level ground.

To check the LMI against the printed rated capacity manual requires moving the crane into a position which aligns with the configuration stated on the manual. The table below gives a range of values which can be expected based on the inputs provided. Note that values are subject to change.

Duty	101	101
Chart	Static	Static
Boom length	11.0m	15.0m
Boom angle	30°	40°
Articulation	20°	10°
Roll	-2° to 2°	-2° to 2°
Pitch	-2° to 0°	-2° to 0°
Rated capacity	12.1t to 12.6t	8.4t to 8.8t

RATED CAPACITY CHART STATIC (0 km/hr) - FALL BLOCK

Duty: **101**
FB

Rad	BOOM LENGTH TO HEAD SHEAVES - 3rd BOOM RETRACTED														3rd BOOM EXTENDING				Rad
	7.23	7.50	8.00	8.50	9.00	9.50	10.00	10.50	11.00	12.00	13.00	14.00	15.00	16.00	17.00	18.00	19.83		
1.0	35000	35000	35000	35000	35000	35000													
	35000	35000	33000	28700	25500	23000													
	47	49	52	55	57	59													
2.0	35000	35000	35000	35000	35000	34900	34300	33700	33100										
	34400	30800	26100	22900	20500	18500	17000	15600	14500										
	34	37	42	46	49	52	54	56	58										
2.5	30200	30300	30300	30400	30100	29600	29100	28600	28200	27400									
	29400	29500	29500	29600	29300	25500	22600	20400	18500	15700									
	27800	27900	24300	21100	18800	17000	15600	14400	13400	11700									
3.0	24700	24800	24800	24900	24900	25000	25000	24800	24500	23800	23200								
	24000	24100	24200	24200	24300	24300	22000	19700	17900	15100	13100								
	22700	22800	22900	19900	17600	15900	14500	13400	12400	10900	9700								
3.5	23800	21700	20900	21000	21000	21100	21100	21100	21000	20500	20100								
	23200	21100	20400	20400	20500	20500	20500	19300	17400	14700	12700	11200							
	21900	19900	19200	19300	16800	15000	13600	12600	11700	10200	9100	8200							
4.0	(3.1)	(3.4)	19	28	34	38	42	45	48	52	56	59							
			18600	18000	18100	18100	18200	18200	18200	18200	18200	18000	17600						
			18100	17500	17600	17600	17700	17700	17100	14300	12300	10900	9700						
5.0			17100	16500	16500	14400	13000	11900	11000	9600	8600	7700	7000						
			(3.9)	19	27	33	37	41	44	49	53	56	59						
			16200	14400	14000	14000	14100	14100	14100	14100	14200	14200	14200	14200					
6.0			15800	14000	13600	13600	13700	13700	13700	11800	10300	9200	8300	7700					
			14900	13100	12800	12400	11100	10100	8700	7700	6900	6300	5800	5500					
			(4.4)	(4.9)	18	26	31	36	42	47	51	54	57	59					
7.0			12800	11500	11300	11300	11400	11400	11400	11400	11400	11500	11600	11800					
			12500	11200	11000	11000	11000	11100	11000	11000	10000	8800	7900	7300	6800				
			11700	10500	10300	9800	8200	7100	6300	5700	5300	5000	4800						
8.0			(5.4)	(5.9)	17	25	34	40	45	49	52	55	58						
			10500	9600	9400	9400	9500	9500	9500	9500	9500	9700	9800	10000					
			10200	9300	9100	9200	9200	8600	7700	7000	6500	6000	5800						
9.0			9500	8700	8000	6700	5900	5300	4800	4600	4400	4000							
			(6.4)	(6.9)	24	33	39	44	48	51	54	58							
			8100	8000	8000	8000	8100	8200	8100	8200	8300	8500							
10.0			7800	7700	7700	7800	7500	6900	6300	5600									
			7300	6700	5600	5000	4500	4300	4000	3700									
			(7.9)	23	32	38	42	46	50	54									
11.0			6900	6800	6900	6900	7000	7200	7300										
			6700	6600	6600	6700	6800	6200	5400										
			6200	5600	4800	4300	4000	3800	3500										
12.0			(8.9)	22	31	37	41	45	51										
			6000	5900	6000	6100	6200	6400											
			5800	5700	5800	5900	6000	5300											
13.0			5400	4800	4100	3800	3600	3200											
			(9.9)	21	30	36	40	47											
			5300	5200	5400	5500	5600												
14.0			5100	5100	5200	5300	5200												
			4700	4200	3700	3400	3100												
			(10.9)	21	29	35	42												
15.0			4700	4700	4800	5000													
			4500	4600	4700	4800													
			4200	3700	3300	2900													
15.683			(11.9)	20	28	38													
			4200	4300	4500														
			4100	4200	4300														
16.883			3800	3400	2800														
			(12.9)	20	32														
			3900	4000															
18.0			3500	2800															
			(13.9)	26															
			3600																
19.83			2900																
			17																
			3300																
		3000																	
		0																	
		13.00	14.00	15.00	16.00	17.00	18.00	19.83											

WINCH RATED CAPACITY

2 FALLS	8700
4 FALLS	17500
6 FALLS	26200
7 FALLS	30600
8 FALLS	35000

UNITS:

- ANGLES IN DEGREES
- LENGTHS IN METRES
- LOAD IN KILOGRAMS

KEY:

14200	RC @ ARTIC:	0°	PITCH:	-2.3	ROLL:	-1.0
10300	RC @ ARTIC:	20°	PITCH:	-2.3	ROLL:	-3.0
6900	RC @ ARTIC:	35°	PITCH:	-2.3	ROLL:	-3.5
51	BOOM ANGLE					
(3.1)	RADIUS AT ZERO BOOM ANGLE					

Note: Pitch & Roll angles indicated are representative of lifts based on firm level ground with tyres at specified pressures.

RATED CAPACITY CHART PICK AND CARRY (0 - 1.44 km/hr) - FALL BLOCK



Rad	BOOM LENGTH TO HEAD SHEAVES - 3rd BOOM RETRACTED														3rd BOOM EXTENDING				Rad
	7.23	7.50	8.00	8.50	9.00	9.50	10.00	10.50	11.00	12.00	13.00	14.00	15.00	16.00	17.00	18.00	19.83		
1.0	35000	35000	35000	35000	35000	35000												1.0	
	35000	33300	28500	25000	22300	20100													
	47	49	52	55	57	59													
2.0	34100	34200	34200	34300	34300	33600	33000	32300	31800									2.0	
	30600	27400	23300	20500	18300	16600	15200	14000	13000										
	34	37	42	46	49	52	54	56	58										
2.5	26800	26900	26900	27000	27000	27000	27100	27100	27100	26300								2.5	
	26100	26200	26200	26300	25400	22200	19800	17800	16300	13800									
	24700	24800	21900	19100	17000	15400	14100	13000	12100	10600									
3.0	22000	22000	22100	22100	22200	22200	22200	22200	22300	22300								3.0	
	21400	21400	21500	21500	21600	21600	19400	17400	15800	13400	11600								
	20200	20200	20300	18200	16000	14400	13200	12200	11300	9900	8800								
3.5	21200	19300	18600	18600	18700	18700	18700	18800	18800	18800	18800							3.5	
	20600	18800	18100	18100	18200	18200	18200	17100	15500	13000	11300	9900							
	19500	17700	17100	17100	15400	13800	12500	11500	10600	9300	8300	7400							
4.0	(3.1)	(3.4)	19	28	34	38	42	45	48	52	56	59						4.0	
			16500	16000	16100	16100	16100	16200	16200	16200	16200	16200							
			16100	15600	15600	15700	15700	15700	15300	12800	11000	9700	8600						
5.0			15200	14700	14800	13300	12000	10900	10100	8800	7800	7000	6400					5.0	
			(3.9)	19	27	33	37	41	44	49	53	56	59						
			14400	12800	12400	12500	12500	12500	12500	12600	12600	12600	12600	12800					
6.0			14000	12400	12100	12100	12100	12100	12200	12200	10600	9300	8200	7400	6800			6.0	
			13200	11700	11400	11400	10300	9400	8000	7100	6300	5700	5300	5000					
			(4.4)	(4.9)	18	26	31	36	42	47	51	54	57	59					
7.0						11400	10300	10000	10100	10100	10100	10200	10200	10200	10300	10400		7.0	
						11100	10000	9800	9800	9800	9800	9000	7900	7100	6600	6100			
						10400	9400	9200	9200	7600	6600	5800	5200	4800	4500	4300			
8.0						(5.4)	(5.9)	17	25	34	40	45	49	52	55	58		8.0	
						9300	8500	8400	8400	8400	8400	8500	8600	8700	8900				
						9000	8200	8100	8100	8200	7800	6900	6300	5900	5200				
9.0						8500	7700	7500	6300	5500	4900	4400	4200	4000	3700			9.0	
						(6.4)	(6.9)	24	33	39	44	48	51	54	58				
						7200	7100	7100	7200	7300	7400	7500							
10.0						6900	6900	6900	6900	6800	6200	5700	5000					10.0	
						6500	6300	5200	4600	4100	3900	3700	3400						
						(7.9)	23	32	38	42	46	50	54						
11.0						6100	6100	6100	6100	6300	6400	6500						11.0	
						5900	5900	5900	5900	6100	5600	4900							
						5500	5300	4400	3900	3700	3500	3200							
12.0						(8.9)	22	31	37	41	45	51						12.0	
						5300	5300	5300	5400	5500	5700								
						5200	5100	5100	5300	5400	5400	4800							
13.0						4800	4500	3800	3500	3300	3000							13.0	
						(9.9)	21	30	36	40	47								
						4700	4700	4800	4900	5000									
14.0						4500	4500	4600	4700	4800								14.0	
						4200	3900	3400	3200	2800									
						(10.9)	21	29	35	42									
15.0						4100	4200	4300	4500									15.0	
						4000	4100	4200	4300										
						3700	3500	3100	2700										
15.683						(11.9)	20	28	38									15.683	
						3800	3800	4000											
						3600	3700	3800											
0						3400	3200	2600										0	
						(12.9)	20	32											
						3400	3600												
13.00						3100	2600											13.00	
						(13.9)	26												
						3100	2700												

WINCH RATED CAPACITY

2 FALLS	8700
4 FALLS	17500
6 FALLS	26200
7 FALLS	30600
8 FALLS	35000

- UNITS:
 - ANGLES IN DEGREES
 - LENGTHS IN METRES
 - LOAD IN KILOGRAMS

KEY:

12600	RC @ ARTIC:	0°	PITCH:	-2.3	ROLL:	-1.0
9300	RC @ ARTIC:	20°	PITCH:	-2.3	ROLL:	-3.0
6300	RC @ ARTIC:	35°	PITCH:	-2.3	ROLL:	-3.5
51	BOOM ANGLE					
(3.1)	RADIUS AT ZERO BOOM ANGLE					

Note: Pitch & Roll angles indicated are representative of lifts based on firm level ground with tyres at specified pressures.

RATED CAPACITY CHART STATIC (0 km/hr) - RHINO HOOK

Duty: **102**
RH20

Rad	BOOM LENGTH TO RHINO HOOK CENTRE - 3rd BOOM RETRACTED														3rd BOOM EXTENDING				Rad
	7.51	8.00	8.50	9.00	9.50	10.00	10.50	11.00	11.50	12.50	13.50	14.50	15.50	16.50	17.50	18.50	20.11		
1.0	20000	20000	20000	20000	20000														
	20000	20000	20000	20000	20000														
	50	53	55	58	60														
2.0	20000	20000	20000	20000	20000	20000	20000	20000	20000										
	20000	20000	20000	20000	18600	17000	15700	14500	13500										
	38	43	46	49	52	54	56	58	60										
2.5	20000	20000	20000	20000	20000	20000	20000	20000	20000	20000									
	20000	20000	20000	20000	20000	20000	20000	18500	17000	14500									
	20000	20000	20000	18900	17100	15600	14400	13400	12500	11000									
3.0	20000	20000	20000	20000	20000	20000	20000	20000	20000	20000	20000								
	20000	20000	20000	20000	20000	20000	19700	17900	16400	14000	12200								
	20000	20000	20000	17700	15900	14500	13400	12400	11600	10200	9100								
3.5	20000	20000	20000	20000	20000	20000	20000	20000	20000	20000	20000	19800							
	20000	20000	20000	20000	20000	20000	19200	17400	15900	13500	11800	10500							
	19900	19300	19300	16800	15000	13600	12500	11600	10800	9600	8600	7700							
4.0	(3.4)	(3.9)	29	34	39	43	46	48	51	54	58	60							
			18100	18100	18100	18200	18200	18200	18200	18200	18100	17700	17300						
			17600	17600	17600	17700	17700	17700	17100	15500	13200	11500	10100	9100					
5.0			16600	16500	14400	13000	11900	11000	10200	9000	8000	7300	6600						
			(4.4)	28	33	38	41	45	47	52	55	58	60						
				14300	14000	14000	14000	14100	14100	14100	14100	14100	14100	14100	14000				
6.0				13900	13600	13600	13600	13700	13700	12700	10900	9600	8600	7800	7200				
				13100	12800	12400	11100	10100	9300	8100	7200	6500	5900	5500	5200				
				(4.9)	(5.4)	26	32	36	40	45	50	53	56	59	61				
7.0						11500	11300	11300	11300	11300	11300	11400	11400	11400	11600	11700			
						11200	10900	11000	11000	11000	10600	9200	8200	7400	6900	6400			
						10500	10300	9800	8800	7500	6600	5900	5400	4900	4700	4500			
8.0						(5.9)	(6.4)	25	30	38	43	48	51	54	57	59			
								9500	9300	9400	9400	9400	9400	9500	9600	9700	9900		
								9200	9000	9100	9100	9100	8900	8200	7400	6600	6100	5500	
9.0								8600	8500	7200	6200	5500	4900	4500	4300	4100	3800		
								(6.9)	(7.4)	29	37	42	46	50	53	55	59		
										7900	7900	7900	7900	8000	8100	8200	8400		
10.0										7600	7600	7700	7700	7000	6400	5900	5300		
										7100	6000	5200	4600	4200	3900	3700	3500		
										(8.4)	28	35	41	45	48	51	55		
11.0																			
12.0																			
13.0																			
14.0																			
15.0																			
15.966																			

UNITS:
 - ANGLES IN DEGREES
 - LENGTHS IN METRES
 - LOAD IN KILOGRAMS

KEY:
14100 RC @ ARTIC: 0° PITCH: -2.3 ROLL: -1.0
9600 RC @ ARTIC: 20° PITCH: -2.3 ROLL: -3.0
6500 RC @ ARTIC: 35° PITCH: -2.3 ROLL: -3.5
53 BOOM ANGLE
(3.4) RADIUS AT ZERO BOOM ANGLE

Note: Pitch & Roll angles indicated are representative of lifts based on firm level ground with tyres at specified pressures.

RATED CAPACITY CHART PICK AND CARRY (0 - 1.44 km/hr) - RHINO HOOK

Duty: **102**
 **RH20**

Rad	BOOM LENGTH TO RHINO HOOK CENTRE - 3rd BOOM RETRACTED														3rd BOOM EXTENDING				Rad
	7.51	8.00	8.50	9.00	9.50	10.00	10.50	11.00	11.50	12.50	13.50	14.50	15.50	16.50	17.50	18.50	20.11		
1.0	20000	20000	20000	20000	20000														
	20000	20000	20000	20000	20000														
	50	53	55	58	60														
2.0	20000	20000	20000	20000	20000	20000	20000	20000	20000										
	20000	20000	19200	18400	16600	15200	14000	13000	12100										
	38	43	46	49	52	54	56	58	60										
2.5	20000	20000	20000	20000	20000	20000	20000	20000	20000	20000									
	20000	20000	20000	20000	20000	19800	17800	16200	14900	12800									
	20000	20000	19200	17000	15400	14100	13000	12000	11200	9900									
	31	37	41	45	48	51	53	55	57	60									
3.0	20000	20000	20000	20000	20000	20000	20000	20000	20000	20000	20000								
	20000	20000	20000	20000	20000	19300	17400	15800	14400	12400	10800								
	20000	20000	18200	16100	14500	13200	12100	11200	10500	9200	8200								
	21	30	35	40	44	47	49	52	54	57	60								
3.5	19300	18600	18700	18700	18700	18700	18800	18800	18800	18800	18800	18800							
	18700	18100	18200	18200	18200	18200	17100	15400	14100	12000	10500	9300							
	17700	17100	17200	15400	13800	12500	11400	10600	9900	8700	7700	7000							
	(3.4)	(3.9)	29	34	39	43	46	48	51	54	58	60							
4.0			16000	16100	16100	16100	16100	16200	16200	16200	16200	16200	16200						
			15600	15600	15700	15700	15700	15200	13800	11700	10200	9000	8000						
			14700	14800	13300	12000	10900	10100	9300	8200	7300	6600	6000						
		(4.4)	28	33	38	41	45	47	52	55	58	60							
5.0				12700	12400	12400	12500	12500	12500	12500	12500	12500	12600	12700					
				12400	12100	12100	12100	12100	12100	11400	9800	8600	7600	6900	6400				
				11600	11400	11400	10300	9300	8600	7500	6600	5900	5400	4900	4700				
			(4.9)	(5.4)	26	32	36	40	45	50	53	56	59	61					
6.0						10200	10000	10000	10000	10100	10100	10100	10100	10200	10300	10400			
						9900	9700	9700	9700	9700	9800	9600	8300	7300	6600	6100	5700		
						9300	9100	9100	8200	6900	6100	5400	4900	4500	4200	4000			
					(5.9)	(6.4)	25	30	38	43	48	51	54	57	59				
7.0								8400	8300	8300	8300	8300	8400	8400	8500	8600	8800		
								8200	8000	8100	8100	8100	7200	6400	5900	5500	4900		
								7700	7500	6700	5700	5000	4500	4100	3900	3700	3400		
							(6.9)	(7.4)	29	37	42	46	50	53	55	59			
8.0										7000	7000	7000	7000	7100	7200	7300	7400		
										6800	6800	6800	6800	6300	5800	5300	4700		
										6300	5600	4800	4200	3800	3600	3400	3100		
									(8.4)	28	35	41	45	48	51	55			
9.0												6000	6000	6000	6100	6200	6300	6400	
												5800	5800	5800	5900	5700	5200	4600	
												5400	4700	4000	3600	3400	3200	2900	
											(9.4)	27	34	39	44	47	52		
10.0													5200	5200	5200	5400	5400	5600	
													5000	5000	5100	5200	5200	4500	
													4600	4000	3500	3200	3000	2700	
											(10.4)	26	33	38	42	48			
11.0														4500	4600	4700	4800	4900	
														4300	4400	4500	4600	4500	
														4000	3400	3100	2900	2600	
											(11.4)	26	32	37	43				
12.0															4000	4100	4200	4300	
															3900	4000	4100	4200	
															3600	3100	2800	2500	
											(12.4)	25	32	39					
13.0																3600	3700	3800	
																3500	3600	3700	
																3200	2800	2400	
														(13.4)	24	34			
14.0																	3300	3400	
																	2900	2300	
															(14.4)	28			
15.0																		3100	
																		2400	
																		20	
15.966																		2800	
																		2400	
																		0	

- UNITS:
 - ANGLES IN DEGREES
 - LENGTHS IN METRES
 - LOAD IN KILOGRAMS

KEY:

12500	RC @ ARTIC: 0°	PITCH: -2.3	ROLL: -1.0
8600	RC @ ARTIC: 20°	PITCH: -2.3	ROLL: -3.0
5900	RC @ ARTIC: 35°	PITCH: -2.3	ROLL: -3.5
53	BOOM ANGLE		
(3.4)	RADIUS AT ZERO BOOM ANGLE		

Note: Pitch & Roll angles indicated are representative of lifts based on firm level ground with tyres at specified pressures.

RATED CAPACITY CHART STATIC (0 km/hr) - RHINO HOOK

Duty: **103**
RH15

Rad	BOOM LENGTH TO RHINO HOOK CENTRE - 3rd BOOM RETRACTED														3rd BOOM EXTENDING				Rad
	7.51	8.00	8.50	9.00	9.50	10.00	10.50	11.00	11.50	12.50	13.50	14.50	15.50	16.50	17.50	18.50	20.11		
1.0	15000	15000	15000	15000	15000														1.0
	15000	15000	15000	15000	15000														
	50	53	55	58	60														
2.0	15000	15000	15000	15000	15000	15000	15000	15000	15000										2.0
	15000	15000	15000	15000	15000	15000	15000	14500	13500										
	38	43	46	49	52	54	56	58	60										
2.5	15000	15000	15000	15000	15000	15000	15000	15000	15000	15000									2.5
	15000	15000	15000	15000	15000	15000	15000	15000	14500										
	31	37	41	45	48	51	53	55	57	60									
3.0	15000	15000	15000	15000	15000	15000	15000	15000	15000	15000	15000								3.0
	15000	15000	15000	15000	15000	15000	15000	15000	15000	14000	12200								
	15000	15000	15000	15000	15000	14500	13400	12400	11600	10200	9100								
3.5	15000	15000	15000	15000	15000	15000	15000	15000	15000	15000	15000	15000							3.5
	15000	15000	15000	15000	15000	15000	15000	15000	15000	13500	11800	10500							
	15000	15000	15000	15000	15000	13600	12500	11600	10800	9600	8600	7700							
4.0	(3.4)	(3.9)	29	34	39	43	46	48	51	54	58	60							4.0
			15000	15000	15000	15000	15000	15000	15000	15000	15000	15000	15000						
			15000	15000	15000	15000	15000	15000	15000	15000	15000	15000	15000	15000	15000	15000	15000	15000	
5.0				14300	14000	14000	14000	14100	14100	14100	14100	14100	14100	14100	14100	14000			5.0
				13900	13600	13600	13600	13700	13700	13700	12700	10900	9600	8600	7800	7200			
				13100	12800	12400	11100	10100	9300	8100	7200	6500	5900	5500	5200				
6.0				(4.9)	(5.4)	26	32	36	40	45	50	53	56	59	61				6.0
						11500	11300	11300	11300	11300	11300	11400	11400	11400	11600	11700			
						11200	10900	11000	11000	11000	11000	10600	9200	8200	7400	6900	6400		
7.0						(5.9)	(6.4)	25	30	38	43	48	51	54	57	59			7.0
								9500	9300	9400	9400	9400	9400	9500	9600	9700	9900		
								9200	9000	9100	9100	9100	7900	7100	6600	6100	5500		
8.0								8600	8500	7200	6200	5500	4900	4500	4300	4100	3800		8.0
								(6.9)	(7.4)	29	37	42	46	50	53	55	59		
										7900	7900	7900	7900	8000	8100	8200	8400		
9.0										7600	7600	7700	7700	7000	6400	5900	5300		9.0
										7100	6000	5200	4600	4200	3900	3700	3500		
										(8.4)	28	35	41	45	48	51	55		
10.0																			10.0
11.0																			11.0
12.0																			12.0
13.0																			13.0
14.0																			14.0
15.0																			15.0
15.966																			15.966

UNITS:

- ANGLES IN DEGREES
- LENGTHS IN METRES
- LOAD IN KILOGRAMS

KEY:

14100	RC @ ARTIC: 0°	PITCH: -2.3	ROLL: -1.0
9600	RC @ ARTIC: 20°	PITCH: -2.3	ROLL: -3.0
6500	RC @ ARTIC: 35°	PITCH: -2.3	ROLL: -3.5
53	BOOM ANGLE		
(3.4)	RADIUS AT ZERO BOOM ANGLE		

Note: Pitch & Roll angles indicated are representative of lifts based on firm level ground with tyres at specified pressures.

RATED CAPACITY CHART PICK AND CARRY (0 - 1.44 km/hr) - RHINO HOOK



Rad	BOOM LENGTH TO RHINO HOOK CENTRE - 3rd BOOM RETRACTED													3rd BOOM EXTENDING				Rad	
	7.51	8.00	8.50	9.00	9.50	10.00	10.50	11.00	11.50	12.50	13.50	14.50	15.50	16.50	17.50	18.50	20.11		
1.0	15000	15000	15000	15000	15000														1.0
	15000	15000	15000	15000	15000														
	50	53	55	58	60														
2.0	15000	15000	15000	15000	15000	15000	15000	15000	15000										2.0
	15000	15000	15000	15000	15000	15000	14000	13000	12100										
	38	43	46	49	52	54	56	58	60										
2.5	15000	15000	15000	15000	15000	15000	15000	15000	15000	15000									2.5
	15000	15000	15000	15000	15000	15000	15000	15000	14900	12800									
	15000	15000	15000	15000	15000	14100	13000	12000	11200	9900									
3.0	15000	15000	15000	15000	15000	15000	15000	15000	15000	15000	15000								3.0
	15000	15000	15000	15000	15000	15000	15000	15000	14400	12400	10800								
	15000	15000	15000	15000	14500	13200	12100	11200	10500	9200	8200								
3.5	15000	15000	15000	15000	15000	15000	15000	15000	15000	15000	15000	15000							3.5
	15000	15000	15000	15000	15000	15000	15000	15000	14100	12000	10500	9300							
	15000	15000	15000	15000	13800	12500	11400	10600	9900	8700	7700	7000							
4.0	(3.4)	(3.9)	29	34	39	43	46	48	51	54	58	60							4.0
			15000	15000	15000	15000	15000	15000	15000	15000	15000	15000	15000						
			15000	15000	15000	15000	15000	15000	13800	11700	10200	9000	8000						
5.0																			5.0
				12700	12400	12400	12500	12500	12500	12500	12500	12500	12600	12700					
				12400	12100	12100	12100	12100	12100	11400	9800	8600	7600	6900	6400				
6.0				11600	11400	11400	10300	9300	8600	7500	6600	5900	5400	4900	4700				6.0
				(4.9)	(5.4)	26	32	36	40	45	50	53	56	59	61				
						10200	10000	10000	10000	10100	10100	10100	10100	10200	10300	10400			
7.0																			7.0
									8400	8300	8300	8300	8300	8400	8400	8500	8600	8800	
									8200	8000	8100	8100	8100	7200	6400	5900	5500	4900	
8.0									7700	7500	6700	5700	5000	4500	4100	3900	3700	3400	8.0
									(6.9)	(7.4)	29	37	42	46	50	53	55	59	
											7000	7000	7000	7000	7100	7200	7300	7400	
9.0																			9.0
10.0																			10.0
11.0																			11.0
12.0																			12.0
13.0																			13.0
14.0																			14.0
15.0																			15.0
15.966																			15.966

UNITS:
 - ANGLES IN DEGREES
 - LENGTHS IN METRES
 - LOAD IN KILOGRAMS

KEY:

12500	RC @ ARTIC: 0°	PITCH: -2.3	ROLL: -1.0
8600	RC @ ARTIC: 20°	PITCH: -2.3	ROLL: -3.0
5900	RC @ ARTIC: 35°	PITCH: -2.3	ROLL: -3.5
53	BOOM ANGLE		
(3.4)	RADIUS AT ZERO BOOM ANGLE		

Note: Pitch & Roll angles indicated are representative of lifts based on firm level ground with tyres at specified pressures.

RATED CAPACITY CHART STATIC (0 km/hr) - FIXED LUG (BUTT)

Duty: **110**
FLUG

Rad	RC
1.0	40000
	40000
	39
1.1	40000
	39900
	37
1.2	39700
	39100
	35
1.3	39000
	38400
	34
1.5	37600
	36900
	30
1.7	36300
	35600
	25
1.9	35100
	34300
	20
2.2	33500
	31000
	0

NOTE:

**Front tyres shall be inflated to 903kPa (131psi) to achieve 100% rated capacity lifts.

UNITS:

- ANGLES IN DEGREES
- LENGTHS IN METRES
- LOAD IN KILOGRAMS

KEY:

40000	RC @ ARTIC: 0°	PITCH: -2.3	ROLL: -1.0
39900	RC @ ARTIC: 35°	PITCH: -2.3	ROLL: -3.5
37	Boom Angle		

Note: Pitch & Roll angles indicated are representative of lifts based on firm level ground with tyres at specified pressures.

RATED CAPACITY CHART PICK AND CARRY (0 - 1.44 km/hr) - FIXED LUG (BUTT)



Rad	RC
1.0	40000
	40000
	39
1.1	40000
	39900
	37
1.2	39700
	39100
	35
1.3	39000
	38400
	34
1.5	37600
	36900
	30
1.7	36300
	35600
	25
1.9	34800
	32100
	20
2.2	30000
	27500
	0

NOTE:

**Front tyres shall be inflated to 903kPa (131psi) to achieve 100% rated capacity lifts.

UNITS:

- ANGLES IN DEGREES
- LENGTHS IN METRES
- LOAD IN KILOGRAMS

KEY:

40000	RC @ ARTIC: 0°	PITCH: -2.3	ROLL: -1.0
39900	RC @ ARTIC: 35°	PITCH: -2.3	ROLL: -3.5
37	Boom Angle		

Note: Pitch & Roll angles indicated are representative of lifts based on firm level ground with tyres at specified pressures.

RATED CAPACITY CHART STATIC (0 km/hr) - LUG 1

Duty: **111**
LUG1

Rad	BOOM LENGTH TO LUG 1									Rad
	6.58	7.00	7.50	8.00	8.50	9.00	9.50	10.00	10.83	
1.0	30000	30000	30000	30000	30000	30000	30000			1.0
	30000	30000	30000	30000	25800	22500	19800			
	41	45	49	53	55	58	60			
1.5	30000	30000	30000	30000	30000	30000	30000	30000		1.5
	30000	30000	30000	26400	22600	19800	17500			
	34	39	44	48	51	54	56	58		
2.0	30000	30000	30000	30000	30000	30000	30000	30000	30000	2.0
	30000	30000	30000	30000	30000	27300	23500	20600	16900	
	30000	30000	28600	23700	20300	17700	15700	14100	11900	
	24	31	38	42	46	49	52	55	58	
2.5	30000	29100	28900	28700	28500	27900	27200	26500	25500	2.5
	29100	28300	28100	27900	27700	26500	22600	19700	16200	
	27500	26700	26500	22000	18600	16200	14300	12800	10800	
	(2.4)	21	30	36	41	45	48	51	55	
3.0		24900	23500	23400	23200	23100	22900	22700	21900	3.0
		24200	22900	22700	22500	22400	22100	19100	15600	
		22800	21500	21100	17500	15100	13200	11800	9900	
		(2.9)	21	29	35	40	44	47	51	
3.5			20500	19500	19400	19300	19200	19000	18900	3.5
			19900	19000	18800	18700	18600	18500	15100	
			18700	17800	17000	14300	12400	11000	9200	
			(3.4)	20	29	34	39	43	48	
4.5				17300	14800	14200	14100	14000	13900	4.5
				16800	14300	13800	13700	13600	13400	
				15700	13400	12900	11700	10000	8100	
				(3.9)	(4.4)	19	27	33	40	
5.5						12800	11200	10800	10700	5.5
						12400	10800	10400	10300	
						11600	10100	9700	7600	
						(4.9)	(5.4)	18	30	
6.5								9800	8500	6.5
								8800	7500	
								(5.9)	13	
6.7									8100	6.7
									7200	
									0	
	6.58	7.00	7.50	8.00	8.50	9.00	9.50	10.00	10.83	

UNITS:

- ANGLES IN DEGREES
- LENGTHS IN METRES
- LOAD IN KILOGRAMS

KEY:

19300	RC @ ARTIC: 0°	PITCH: -2.3	ROLL: -1.0
18700	RC @ ARTIC: 20°	PITCH: -2.3	ROLL: -3.0
14300	RC @ ARTIC: 35°	PITCH: -2.3	ROLL: -3.5
34	BOOM ANGLE		
(3.4)	RADIUS AT ZERO BOOM ANGLE		

Note: Pitch & Roll angles indicated are representative of lifts based on firm level ground with tyres at specified pressures.

RATED CAPACITY CHART PICK AND CARRY (0 - 1.44 km/hr) - LUG 1



Rad	BOOM LENGTH TO LUG 1										Rad
	6.58	7.00	7.50	8.00	8.50	9.00	9.50	10.00	10.83		
1.0	30000	30000	30000	30000	30000	30000	30000				1.0
	30000	30000	30000	26000	22300	19500	17200				
	41	45	49	53	55	58	60				
1.5	30000	30000	30000	30000	30000	30000	30000	30000			1.5
	30000	30000	27500	23100	19800	17300	15400	13700			
	34	39	44	48	51	54	56	58			
2.0	30000	30000	30000	30000	30000	30000	30000	30000	29000		2.0
	30000	30000	30000	30000	27600	23300	20100	17600	14600		
	30000	30000	25300	21100	18000	15700	13900	12400	10500		
	24	31	38	42	46	49	52	55	58		
2.5	26600	25900	25700	25500	25300	25200	25100	24900	24600		2.5
	25900	25200	25000	24800	24600	22800	19500	17000	14000		
	24500	23800	23600	19700	16700	14500	12800	11400	9600		
	(2.4)	21	30	36	41	45	48	51	55		
3.0		22100	20900	20800	20600	20500	20400	20300	20100		3.0
		21500	20300	20200	20000	19900	19200	16600	13600		
		20300	19100	19000	15900	13600	11900	10600	8800		
		(2.9)	21	29	35	40	44	47	51		
3.5			18200	17400	17200	17100	17000	16900	16800		3.5
			17700	16900	16700	16600	16500	16400	13300		
			16700	15800	15500	13000	11300	9900	8200		
			(3.4)	20	29	34	39	43	48		
4.5				15400	13100	12600	12500	12500	12300		4.5
				14900	12700	12200	12100	12100	11900		
				14000	11900	11400	10700	9100	7400		
				(3.9)	(4.4)	19	27	33	40		
5.5						11400	9900	9600	9500		5.5
						11000	9600	9300	9200		
						10300	9000	8600	7000		
						(4.9)	(5.4)	18	30		
6.5								8700	7500		6.5
								7800	6700		
								(5.9)	13		
6.7									7200		6.7
									6400		
									0		
	6.58	7.00	7.50	8.00	8.50	9.00	9.50	10.00	10.83		

UNITS:

- ANGLES IN DEGREES
- LENGTHS IN METRES
- LOAD IN KILOGRAMS

KEY:

17100	RC @ ARTIC: 0°	PITCH: -2.3	ROLL: -1.0
16600	RC @ ARTIC: 20°	PITCH: -2.3	ROLL: -3.0
13000	RC @ ARTIC: 35°	PITCH: -2.3	ROLL: -3.5
34	BOOM ANGLE		
(3.4)	RADIUS AT ZERO BOOM ANGLE		

Note: Pitch & Roll angles indicated are representative of lifts based on firm level ground with tyres at specified pressures.